	<b>MARIANO MARCOS STATE UNIVERSITY</b> Procurement Division		Document Code	PD-FRM-002
	Request for Quotation (RFQ) (Goods and Services)		Revision No.	5
			Effectivity Date	April 20, 2022
Page 1 of 2				

**REQUEST FOR QUOTATION (RFQ)**

Date: April 25, 2022  
 TOR No. 2022-04- /49 (05206411)

Sir/Madam:

Please quote your lowest price on the item/s listed below, and submit your quotation duly signed by you or your duly authorized representative not later than **3 days** subject to the Terms and Conditions provided at the last page of this RFQ.

Delivery period must be at least within  60  days upon receipt of the Notice to Proceed or Purchase Order.

For any clarification, you may email us at bac@mmsu.edu.ph.

  
**NATHANIEL R. ALBUYOG**  
 BAC Chair

ITEM	QTY	Unit	ITEM DESCRIPTION	ABC/unit	UNIT PRICE
	1	lot	Provision for Working Laboratory Furniture (please see attached TOR)	165,362.50	

**TOTAL ESTIMATED BUDGET: 165,362.50**

**REMARKS/NOTE:** \_\_\_\_\_  
 \_\_\_\_\_  
 \_\_\_\_\_

After having carefully read and accepted your Terms and Conditions, I/we submit our quotation/s on the item/s at prices indicated above.

Business Name: \_\_\_\_\_  
 Business Address: \_\_\_\_\_  
 Printed Name of the Owner: \_\_\_\_\_  
 Signature over Printed Name  
 TIN: \_\_\_\_\_  
 Tel. No./Cellphone No./e-mail address  
 PhilGEPS Registration Number: \_\_\_\_\_  
 Business Permit: \_\_\_\_\_  
 Omnibus Sworn Statement: \_\_\_\_\_  
 Annual Income Tax Return: \_\_\_\_\_  
 Date

*Disclaimer: Reproduction of this form is allowed subject to compliance to the Documented Information Procedure established by MMSU.*

*Trk No. 2022-04-145*

**TERMS OF REFERENCE**

**I. Project Title:**  
**PROVISION OF WORKING/LABORATORY FURNITURE, MMSU CIT-Paoay Campus, Ilocos Norte**

**II. OVERVIEW**  
The Mariano Marcos State University is in need of Furniture Shop with tools, equipment and competent woodworkers to fabricate working/laboratory furniture for the College of Industrial Technology at Paoay campus.

**III. PURPOSE/OBJECTIVE**  
The College of Industrial Technology has been granted by DENR wooden materials to be used in fabricating working/laboratory furniture. These furnitures are needed in the Paoay campus for training purposes relative to the offering of short-term NC course upon accreditation by TESDA. To maximize the grant provided by DENR, but due to the limited machineries and manpower, the university needs to outsource services to produce these needed furnitures from local shops capable to complete the above-mentioned project.

**IV. BUDGET AND FUNDING**  
The cost of services/quotation should not exceed the Approved Budget for the Contract of **ONE HUNDRED SIXTY FIVE THOUSAND THREE HUNDRED SIXTY TWO AND 50/100 (PHP 165,362.50)** and should cover all requirements enumerated above. Prices are inclusive of taxes and all applicable charges.

**V. MINIMUM REQUIREMENTS**

- Must be able to submit the following requirements:
  - Mayor's / Business Permit
  - PhilGEPS Registration number
  - Income/Business Tax Return (Latest)
- Must have readily available tools and equipment for wood working and finishing works.
- Must have available manpower with appropriate skills and expertise to undertake all item of work.

**VI. SCOPE OF WORK**

1. The contractor shall be responsible for transporting materials from the university to their working area/site. Proper documentation shall be done with the university supply office prior to transferring.
2. Cutting of the logs to needed size and shapes for making the furnitures shall be done by the contractor. All excess materials shall be returned upon completion of the project.
3. The needed furniture's to be assembled as indicated in the approved POW are the following:
  - a. 115 Armchairs
  - b. 24 Bench
  - c. 12 Tables
4. Design of the furnitures shall be according to the approved plan given by the end user.
5. All other items or scope of works not mentioned in this document but shown and/or indicated in the plans, and very vital for the completion of the project the contractor shall likewise furnish all materials, labor and equipment necessary to complete the same.
6. All assembled furnitures shall be fully furnished for the full satisfaction of the end user. The contractor shall show sample and finishes for approval of the end user before mass production.

**VII. DELIVERY**

1. Three days prior to delivery, the contractor must inform the University in writing of the delivery schedule so it can notify appropriate offices for inspection.
2. Time is a very important factor in the implementation of this project and as such, all works indicated in the plans and in this document shall be fully completed within **60 calendar days** from receipt of the Notice to Proceed.
3. All finished products shall be delivered to MMSU-CIT Paoay Campus.
4. If the winning bidder failed to deliver any or all items or perform within the period specified, inclusive of duly granted time extension, if any, the procuring entity shall without prejudice to its other remedies under the applicable laws, deduct from the price, as liquidated damages.

**VIII. GENERAL CONDITIONS OF THE CONTRACT**

1. All entries in the quotation must be handwritten, duly signed by the supplier/dealer or its duly authorized representative;
2. PHILGEPS Registration Certificate shall be attached to the quotation upon submission to the contact person provided in the TOR;
3. For verification purposes, the bidder with the lowest bid shall be required to present the original copy of the required documents upon submission, specified in item V of the Terms of Reference, as appropriate.

**IX. CONDITIONS OF THE CONTRACT**

MMSU reserves the right to reject and/or all quotations/bids, to annul the procurement process, to reject all quotations/bids at any time prior to contract award, without thereby incurring any liability to the affected Bidder(s) and to accept only the offer that is most advantageous to the Government.

Prepared by:

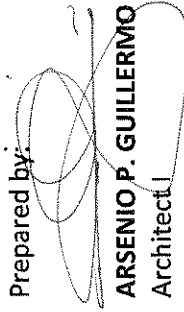
  
**ARSENIO P. GUILLERMO**  
Architect I

Checked and Reviewed by:

  
**AIDA V. CABANG**  
Architect IV, Chief Planning Section

INCLUDED IN THE  
2023 PRMP

Approved by:



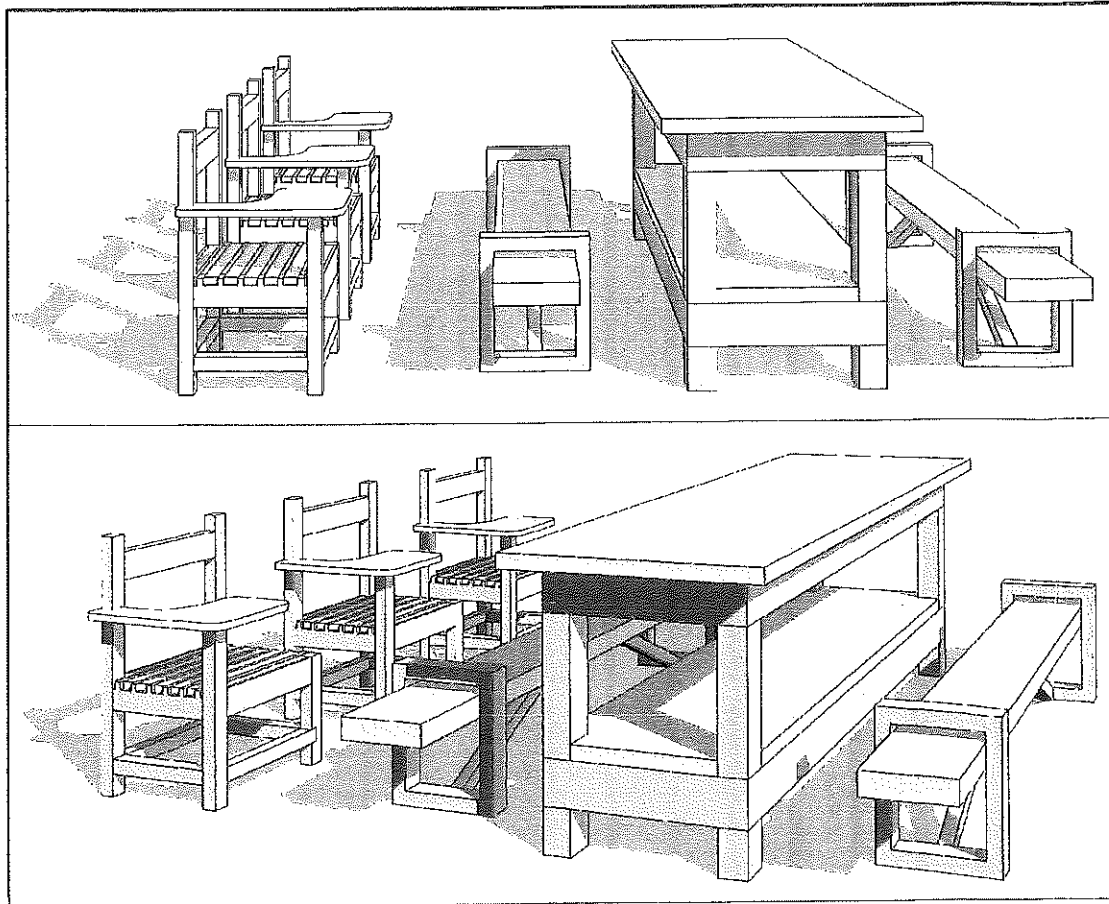

  
**SHIRLEY C. AGRUPIS**  
President  
Mariano Marcos State University

FUNDS AVAILABLE 164  
  
**MELBA M. CORPUZ**  
CHIEF ACCOUNTING OFFICE

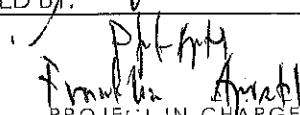

# PERSPECTIVE VIEW

SCALE 1:30 MTRS.

DRAWN BY:  ROMEO J. DOMINGO, JR. INSTRUCTOR III	PROJECT TITLE: <b>PROVISION OF WORKING/LABORATORY TABLE</b>	CONFORME:  CESARIO Y. PACIS DEAN, MMSU - CIT
PREPARED BY:  PROJECT IN-CHARGE	PROJECT LOCATION: MMSU - COLLEGE OF INDUSTRIAL TECHNOLOGY , P. GOMEZ ST. LAOAG CITY, PHILIPPINES	APPROVED BY:  SHIRLEY C. AGRUPIS UNIVERSITY PRESIDENT

TOP VIEW

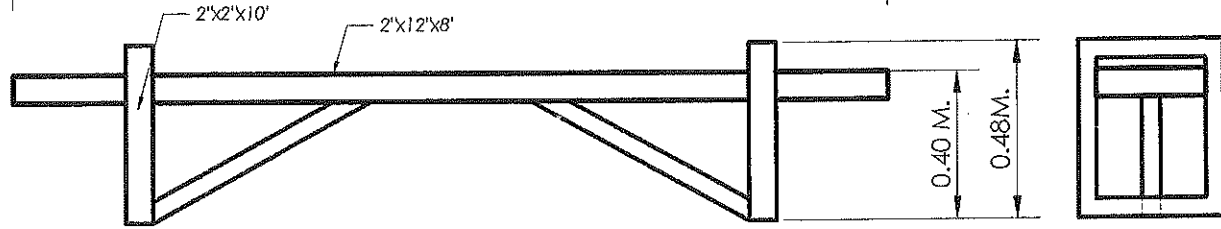
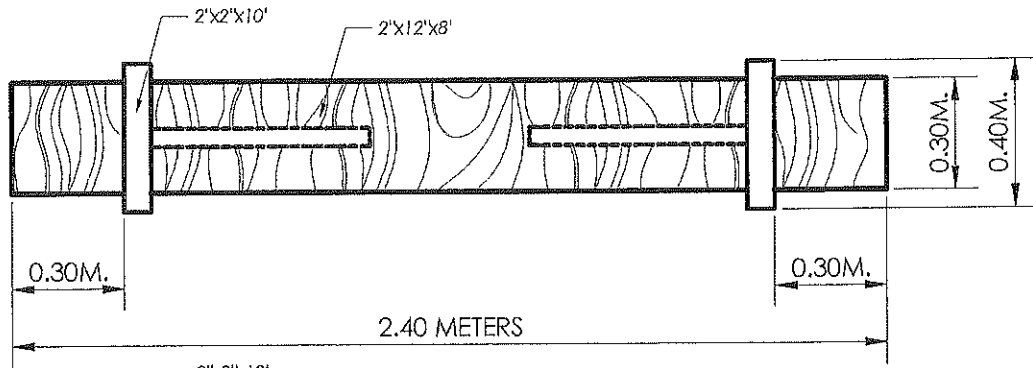

FRONT VIEW

R-SIDE VIEW

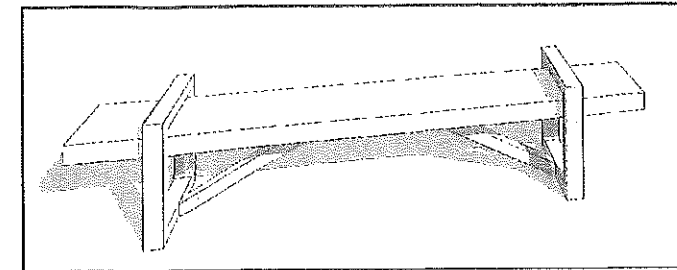





ORTHOGRAPHIC DRAWING

SCALE 1:30 MTRS.

PERSPECTIVE VIEW

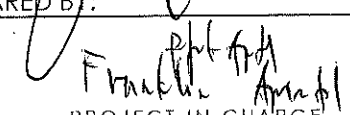
SCALE 1:30 MTRS.

<p>DRAWN BY:</p>  <p>ROMEO J. DOMINGO, JR. INSTRUCTOR III</p>	<p>PROJECT TITLE:</p> <p>PROVISION OF WORKING/LABORATORY TABLE</p>	<p>CONFORME:</p>  <p>CESARIO Y. PACIS DEAN, MMSU - CIT</p>
<p>PREPARED BY:</p>  <p>PROJECT IN-CHARGE</p>	<p>PROJECT LOCATION:</p> <p>MMSU - COLLEGE OF INDUSTRIAL TECHNOLOGY, P. GOMEZ ST. LAOAG CITY, PHILIPPINES</p>	<p>APPROVED BY:</p>  <p>SHIRLEY C. AGRUPIS UNIVERSITY PRESIDENT</p>

TOP VIEW

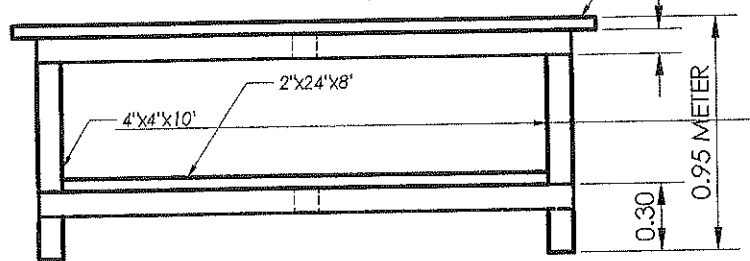
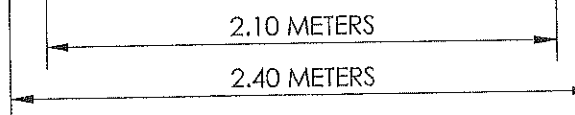
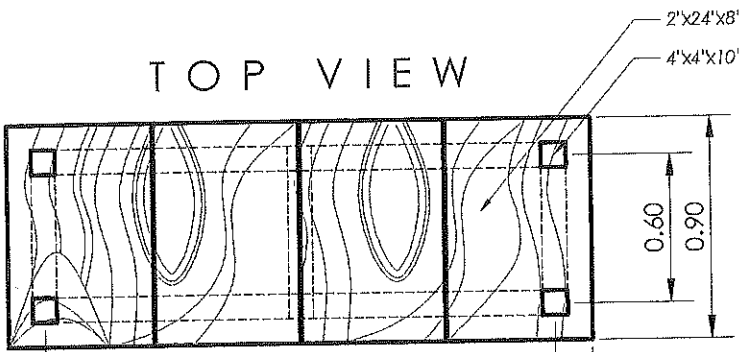

FRONT VIEW

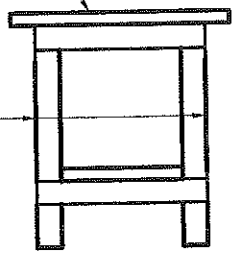

R-SIDE VIEW

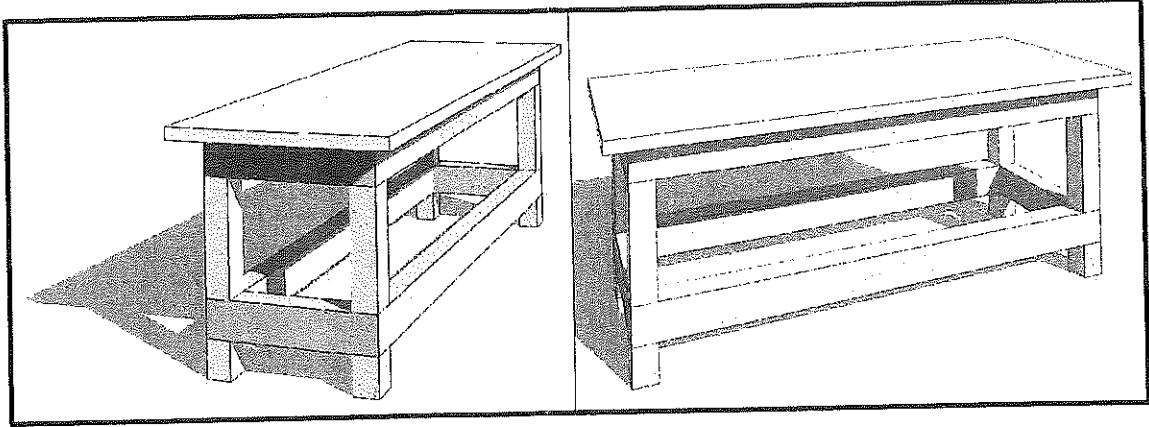

ORTHOGRAPHIC DRAWING

PERSPECTIVE VIEW

SCALE 1:30 MTRS.

SCALE 1:30 MTRS.

DRAWN BY:	PROJECT TITLE:	CONFORME:
 ROMEO DOMINGO, JR. INSTRUCTOR III	PROVISION OF WORKING/LABORATORY TABLE	CESARIO Y PACIS DEAN, MMSU - CIT
PREPARED BY:  PROJECT IN-CHARGE	PROJECT LOCATION: MMSU - COLLEGE OF INDUSTRIAL TECHNOLOGY, P. GOMEZ ST. LAOAG CITY, PHILIPPINES	APPROVED BY:  SHIRLEY C. AGRUPIS UNIVERSITY PRESIDENT